

Diaphragm Pressure Gauges Process Industry Series Sealgaug[®] Type 432.56 - Dry Case Type 433.56 - Liquid-filled case

WIKA Datasheet 43X.56

Applications

- With liquid filled case for applications with high dynamic pressure pulsations or vibration and overpressure
- Suitable in corrosive environments for gaseous, liquid or highly viscous media.
- Process industry: chemical/petrochemical, power stations, mining, on and offshore, environmental technology, mechanical engineering and plant construction

Special features

- Wide selection of special wetted materials
- All stainless steel construction
- High overpressure safety up to 1,500 psi

Standard Features

Design

EN 837-3

Sizes

4" & 6" (100 & 160 mm)

Accuracy class

± 1.5% of span

Ranges

Vacuum / Compound to 200 psi

Pressure from 10" H₂O to 100" H₂O (6" flange diameter)

Pressure from 6 psi to 600 psi (4" flange diameter)
or other equivalent units of pressure or vacuum

Working pressure

Steady: full scale value

Fluctuating: 0.9 x full scale value

Overpressure safety

Choice of 600 psi or 1,500 psi

Operating temperature

Ambient: -4°F to +140°F (-20°C to +60°C)

Medium: +212°F (+100°C) maximum

Temperature error

Additional error when temperature changes from reference temperature of 68°F (20°C) ±0.8% for every 18°F (10°C) rising or falling. Percentage of span.



Diaphragm Pressure Gauge Model 432.56

Weather protection

Weather resistant (NEMA 3 / IP54) - dry case

Weather tight (NEMA 4X / IP65) - liquid-filled case

Pressure connection and lower diaphragm housing

Material: 316 stainless steel

Lower mount (LM)

1/2" NPT female

Upper diaphragm housing

Chrome steel

Diaphragm element

≤ 100" H₂O: 316 stainless steel

> 100" H₂O: Duratherm (NiCrCo-alloy)

with FPM (Viton) sealing gasket

Movement

Stainless steel

Dial

White aluminum with black lettering

Pointer

Black aluminum, adjustable - Type 432.56

Black aluminum, non-adjustable - Type 433.56

Case

304 stainless steel with blowout disk and stainless steel bayonet ring

Window

Laminated safety glass with Buna-N gasket

Case fill

Glycerine - Type 433.56

Optional extras

- Underpressure safe to -30"Hg
- Silicone for fluorolube case filling
- Special connections limited to wrench flat area
- Open flange connections (300# ASME maximum)
- Instrument glass or acrylic window
- Cleaned for oxygen service
- Extended media temperature to +392°F
- Exotic metal or PTFE lining for open flanges
- Alarm contacts switches (magnetic or inductive)
- Special process connections
- Custom dial layout

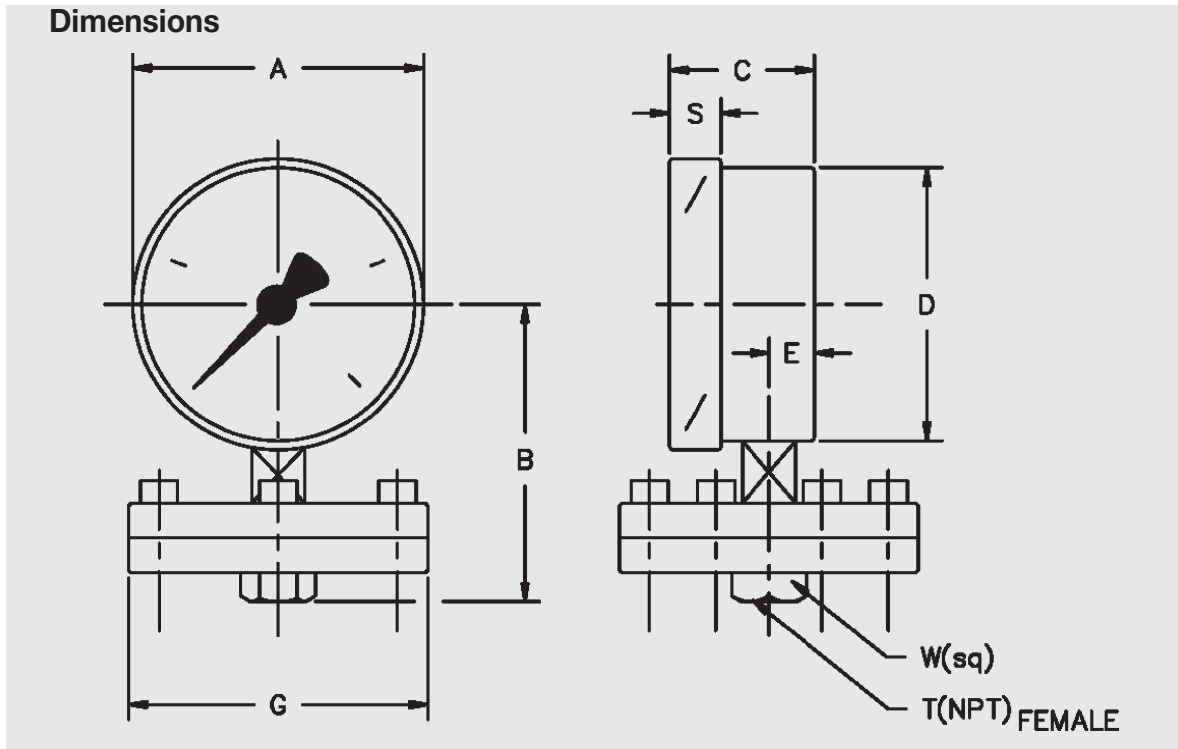
Dimensions

Size		A	B	C	D	E	G ¹	S	T	W	Weight
4"	mm	100	104	49.5	99	15.5	100	17.5		27	
	in	4.0	4.09	1.95	3.90	0.61	3.94	0.69	1/2"	1.06	3.8 lb.
6"	mm	160	134	49.5	159	15.5	100	17.5		27	
	in	6.0	5.28	1.95	6.26	0.61	3.94	0.69	1/2"	1.06	4.9 lb.

¹ For ranges 100"H₂O and lower, G dimension changes to 160 mm (6") and weight increases by 4.0 lb.

Ordering information

Pressure gauge model / Nominal size / Scale range / Size of connection / Optional extras required
 Specifications and dimensions given in this leaflet represent the state of engineering at the time of printing.
 Modifications may take place and materials specified may be replaced by others without prior notice.

**WIKAL Instrument Corporation**

1000 Wiegand Boulevard
 Lawrenceville, GA 30045
 Tel (770) 513-8200 Toll-free 1-888-WIKA-USA
 Fax (770) 338-5118
 E-Mail info@wika.com
 www.wika.com